

KLK 151-S GAS DONER GRILL

RINNOVA

BURNER	4 Burners
WIDTH	550 mm
DEPTH	715 mm
HEIGHT	1065 mm
WEIGHT	40 kg
VOLTAGE	230 V / 50 Hz
CAPACITY	60 kg
CONSUMPTION	1,355m ³ /h
POWER	13,00 kW

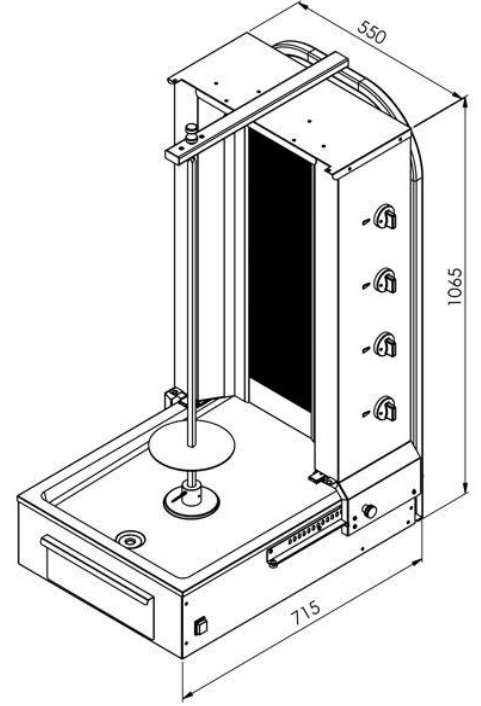

OPTIONAL PARTS	FAT TRAY EXTENSION PART
	WIND WINGS LEFT&RIGHT SET

TECHNICAL SPECIFICATIONS	NATURAL GAS OR PROPAN (LPG)
	12mm SOLID AND STAINLESS SKEWER AND SKEWER PLATE
	OPTIONAL WIND WINGS SET (LEFT&RIGHT)
	OPTIONAL FAT TRAY EXTENSION PART AND STRAINER
	EQUIPPED WITH SAFETY GAS VALVE
	MOTOR AT BOTTOM (REVERSIBLE MOTOR)
	MOVING BODY (BURNERS CAN COME CLOSE TO DONER MEAT)
	STAINLESS STEEL BODY
	AISI-310S Cr-Ni BURNER COVER
	HYGIENIC, SAFE AND LONG LASTING

